

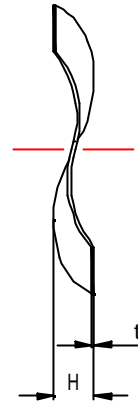

Wave Washers (For bearing use)

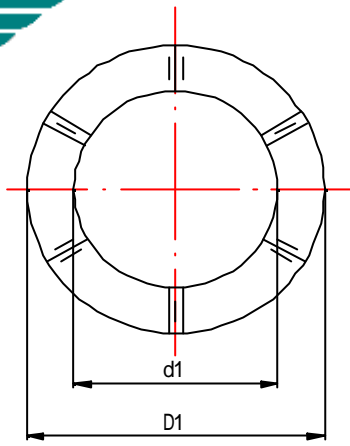

Unit:mm

Size-No.	Bearing out dig	d1	D1	H	t	Applicable bearing Nos.				
B W W- 624	13	8.8	12.8	1.5	0.15	695		624	633	
625	16	12	15	2	0.15			625	634	
626	19	12.7	18.1	2.5	0.2	698	607	626	635	
608	22	14.5	21	2.4	0.2	6900	608	627	636	
629	26	19.5	24.8	3.2	0.2		6000	629	637	
6001	28	20.9	26.9	3	0.25	6902	6001		638	
6200	30	22	28.5	4.1	0.25	6903		6200	639	
6201	32	23.5	30.5	4	0.25		6002	6201		
6202	35	26.4	33.9	3.5	0.3		6003	6202	6300	
6203	40	29.8	38.3	5	0.3			6203		
6302	42	30.1	40.6	4.5	0.3	6905	6004		6302	
6303	47	33.7	45.5	5	0.3	6906	6005	6204	6303	
6304	52	37.5	49	8	0.3			6205	6304	
6305	62	47.2	60.2	6.5	0.4	6908	6007	6206	6305	6403
6306	72	55	70.5	7	0.45	6910		6207	6306	6404
6307	80	61.3	77.8	8.5	0.45	6911	6010	6208	6307	6405
6308	90	69	88.5	7	0.6	6913	6011	6210	6308	6405
6309	100	79.3	98.8	6.5	0.7	6914	6013	6211	6309	6407
6310	110	88.9	108.9	8	0.8	6916	6014	6212	6310	6408
6311	120	95.8	118.9	8.5	0.8	6917		6213	6311	6409
6312	130	108.3	128.3	11	0.8	6919	6017	6215	6312	6410
6313	140	112.4	138.4	11	0.8	6920	6018	6216	6313	6411

Material=Carbon spring steel. Hardness=HRC40~50. Finish=Black phosphate coating (ACP).

Note; 1. Free height H shows when 3 waves are at the same height.

2. Internal diameter d1 shows inscribed circle and outer diameter D1 shows circumscribed circle.

ALL RIGHTS RESERVED

DONGGUAN EAGLE SANKYOU SCREWS AND FASTENERS CO.,LTD.