

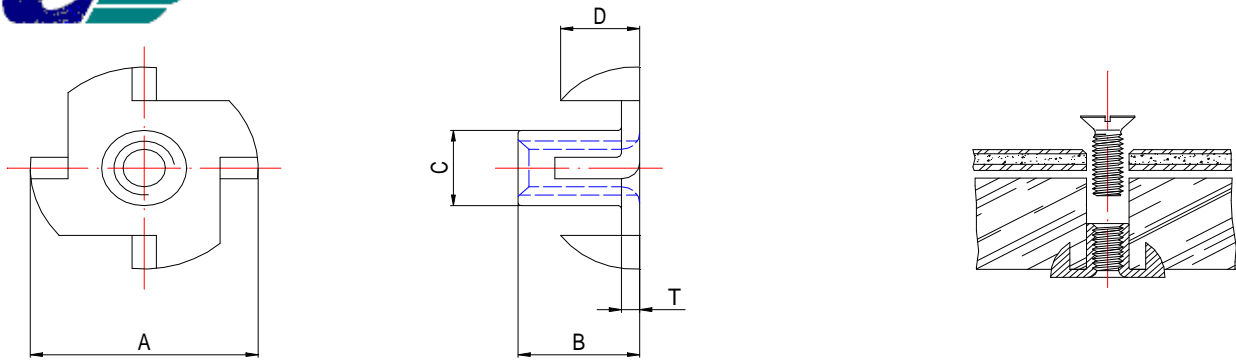

Prong T-Nuts

Installed



Unit: mm

Size-No.	Applicable Screw		A	B	C	D	T	Nos. of Teeth
	mm	inch						
H-4-8	M4 X 0.7		15	8	5.6	5.2	1.2	4
H- $\frac{3}{16}$ - $\frac{5}{16}$		$\frac{3}{16}$ -24	17	9	6.5	6.2	1.2	4
H-5-9	M5 X 0.8		17	9	6.5	6.2	1.2	4
H-6-9	M6 X 1		19	9	7.6	7.2	1.2	4
H- $\frac{1}{4}$ - $\frac{3}{16}$		$\frac{1}{4}$ -20	19	9	7.6	7.2	1.2	4
H-8-11	M8 X 1.25		22.2	11	9.9	8.6	1.6	4
H- $\frac{5}{16}$ - $\frac{3}{8}$		$\frac{5}{16}$ -18	22.2	11	9.9	8.6	1.6	4
H- $\frac{3}{8}$ - $\frac{7}{16}$		$\frac{3}{8}$ -16	25.5	13	11.6	9.5	1.8	4
H-10-13	M10 X 1.5		25.5	13	11.6	9.5	1.8	4

Material= JIS G 3141 SPCC (AISI C1010) Finish=Plain or Zn Plating

Weld Nuts

F(Nonboss type)

B(Boss type)

Installed

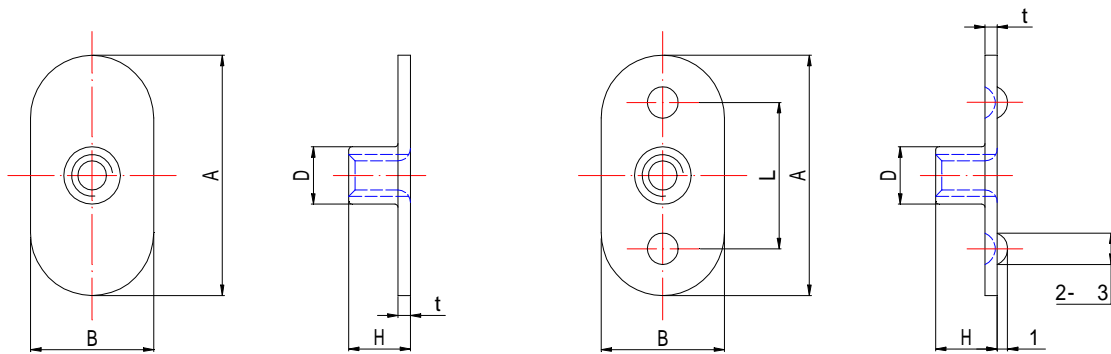

Unit: mm

Size-No.	Applicable screw	A	B	H	D	t	R	L
W-4-F	M4 X 0.7	23	12	6	5.5	1.2	6	-
W-4-B	M4 X 0.7	23	12	6	5.5	1.2	6	14
W-5-F	M5 X 0.8	24	12	7	6.2	1.2	6	-
W-5-B	M5 X 0.8	24	12	7	6.2	1.2	6	16
W-6-F	M6 X 1	26	14	8	7.8	1.6	7	-
W-6-B	M6 X 1	26	14	8	7.8	1.6	7	17
W-8-F	M8 X 1.25	28	14	10	9.6	1.8	7	-
W-8-B	M8 X 1.25	28	14	10	9.6	1.8	7	20

Material= JIS G 3141 SPCC (AISI C1010) Finish=Plain or Zn Plating

Note: Welding bosses may be located on the opposite side, please inquire.

ALL RIGHTS RESERVED

DONGUAN EAGLE SANKYOU SCREWS AND FASTENERS CO.,LTD.