

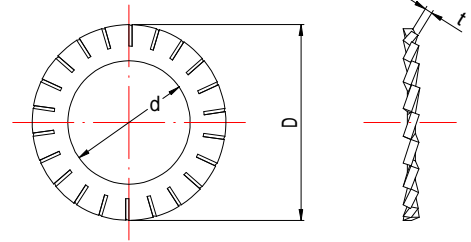

## Overlapping Toothed Lock Washers

Internal type

External type

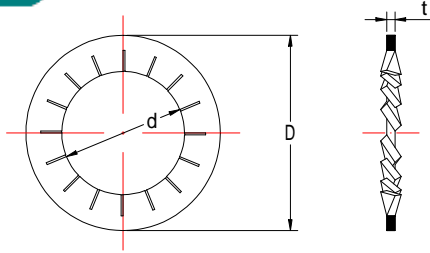

Unit mm

Size-No.		Screw Size		d		D		t		No. of Teeth	
Internal	External	mm	Inch	Max	Min	Max	Min	Max	Min	Internal	External
J Z -3	A Z -3	3		3.35	3.05	6.24	5.76	0.43	0.37	8	10
-4	-4	4	<sup>5</sup> / <sub>32</sub>	4.4	4.1	8.29	7.71	0.53	0.47	8	12
-5	-5	5		5.4	5.1	9.49	8.91	0.63	0.57	8	12
-6	-6	6		6.46	6.1	11.35	10.65	0.73	0.67	10	12
-8	-8	8	<sup>5</sup> / <sub>16</sub>	8.56	8.2	14.35	13.65	0.83	0.77	12	14
-10	-10	10		10.63	10.2	18.35	17.65	0.93	0.87	12	16
-12	-12	12		12.73	12.3	20.42	19.58	1.04	0.96	14	18
-14	-14	14		14.73	14.3	24.42	23.58	1.14	1.06	16	20
-16	-16	16	<sup>5</sup> / <sub>8</sub>	16.73	16.3	26.42	25.58	1.24	1.16	16	20
-18	-18	18		19.02	18.5	30.42	29.58	1.44	1.36	16	20
-20	-20	20		21.02	20.5	33	32	1.44	1.36	16	22
-22	-22	22	<sup>7</sup> / <sub>8</sub>	23.02	22.5	35.5	34.5	1.55	1.45	18	22
-24	-24	24		25.02	24.5	38.5	37.5	1.55	1.45	20	24

Material= Carbon spring steel. Hardness= HRC40~50.

Finish=Black plating coating(ACP).

## Countersunk type

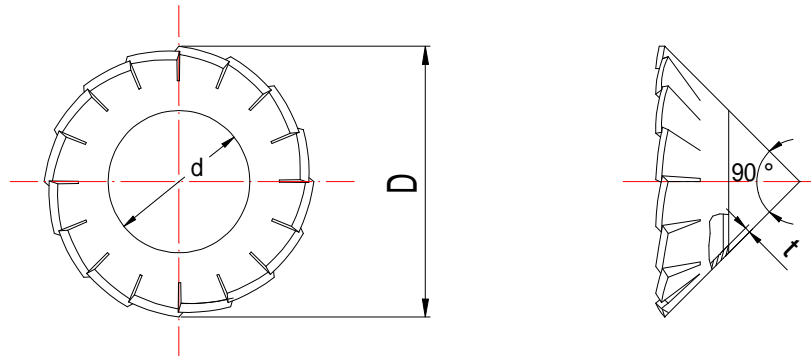

Size-No.	Screw Size		d		D		t		Nos .of Teeth
	mm	Inch	Max	Min	Max	Min	Max	Min	
AZV -4	4	<sup>5</sup> / <sub>32</sub>	4.5	3.9	8.29	7.71	0.27	0.23	14
-5	5		5.5	4.9	10.29	9.71	0.32	0.28	14
-6	6		6.66	5.94	12.35	11.65	0.32	0.28	16

Material=Carbon spring steel. Hardness HRC 40~50.

Finish=Black phosphate coating(ACP).

ALL RIGHTS RESERVED

DONGGUAN EAGLE SANKYOU SCREWS AND FASTENERS CO.,LTD.