

Grip Type Retaining Rings

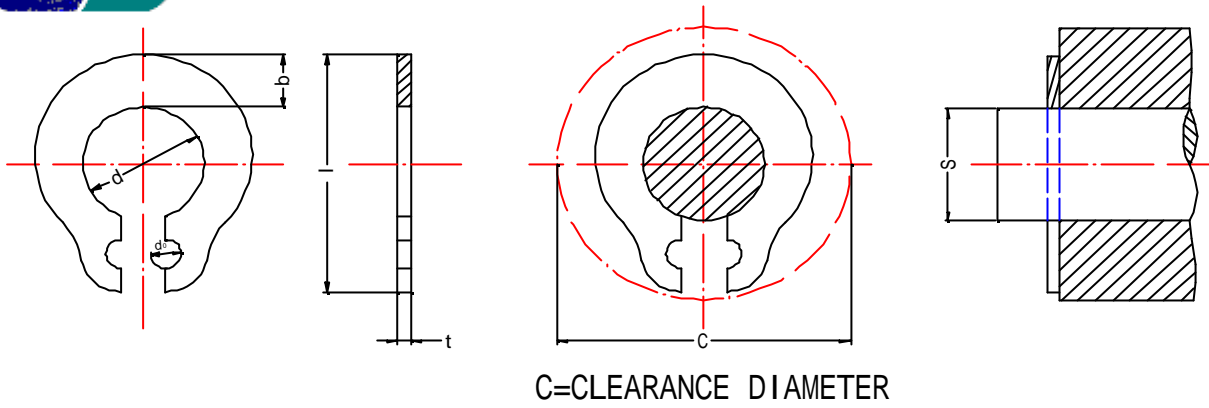

Unit:mm

Size-No.	Ring dimension							C Max.	Applicable shaft		Thrust Load kgf
	d		b	l	do	t			S		
	Max.	Min.				Max.	Min.		Max.	Min.	
GTW- 1.5	1.45	1.32	0.75	3.8	0.9	0.43	0.37	5.3	1.52	1.48	1.5
2	1.93	1.8	1	4.8	0.9	0.64	0.56	6.4	2.02	1.98	2
2.5	2.4	2.27	1.2	5.4	0.9	0.64	0.56	6.8	2.53	2.47	3
3	2.9	2.77	1.4	6.3	0.9	0.64	0.56	7.7	3.03	2.97	4
4	3.85	3.7	1.8	8.4	1.2	0.84	0.76	10.3	4.03	3.97	6
5	4.83	4.67	2.2	9.8	1.2	0.84	0.76	11.4	5.03	4.97	8
6	5.78	5.62	2.4	11.5	1.4	1.05	0.95	13.5	6.03	5.97	10
7	6.8	6.6	2.7	12.8	1.4	1.05	0.95	14.8	7.05	6.95	12
8	7.8	7.6	3	14.1	1.4	1.05	0.95	15.8	8.05	7.95	12
9	8.75	8.55	3.3	16.6	2	1.26	1.14	19.8	9.05	8.95	15
10	9.75	9.55	3.5	17.8	2	1.26	1.14	20.8	10.05	9.95	16

Material=Carbon spring steel. Hardness=HRC44~52. Finish=Black phosphate coating (ACP).

Material=Stainless spring steel.

ALL RIGHTS RESERVED

DONGGUAN EAGLE SANKYOU SCREWS AND FASTENERS CO.,LTD.